

A	B	C	D
1	GF1- 022	438	210
2	GF1- 131	374	414
3	GF1- 132	374	414
4	GF1- 133	357	414
5	GF1- 134	357	414
6	GF1- 210	593	450
7	GF1- 303	444	414
8	GF1- 326	499	414
9	GF1- 403	101	44
10	GF1- 419	444	56
11	GF1- 5001	475	60

A	B	C	D
12	GF1- 5004	475	60
13	GF1- 5007	475	38
14	GF1- 5008	475	38
15	GF1- 5046	475	60
16	GF1- 5047	475	60
17	GF1- 551	400	120
18	GF1- 552	400	120
19	GF1- 553	400	120
20	GF1- 902	401	399
21	GF1- 915	558	391

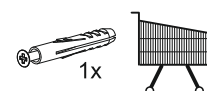

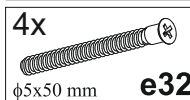
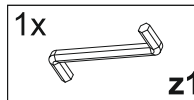
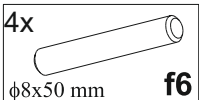
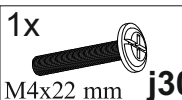
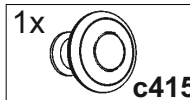
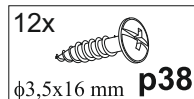
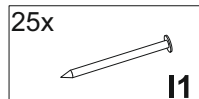
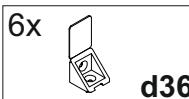
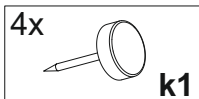
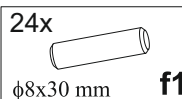
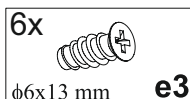
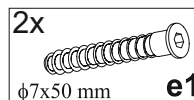
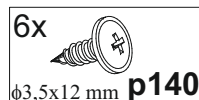
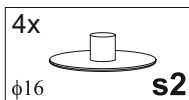
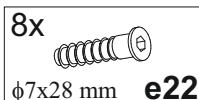
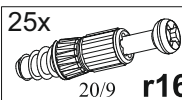
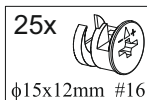
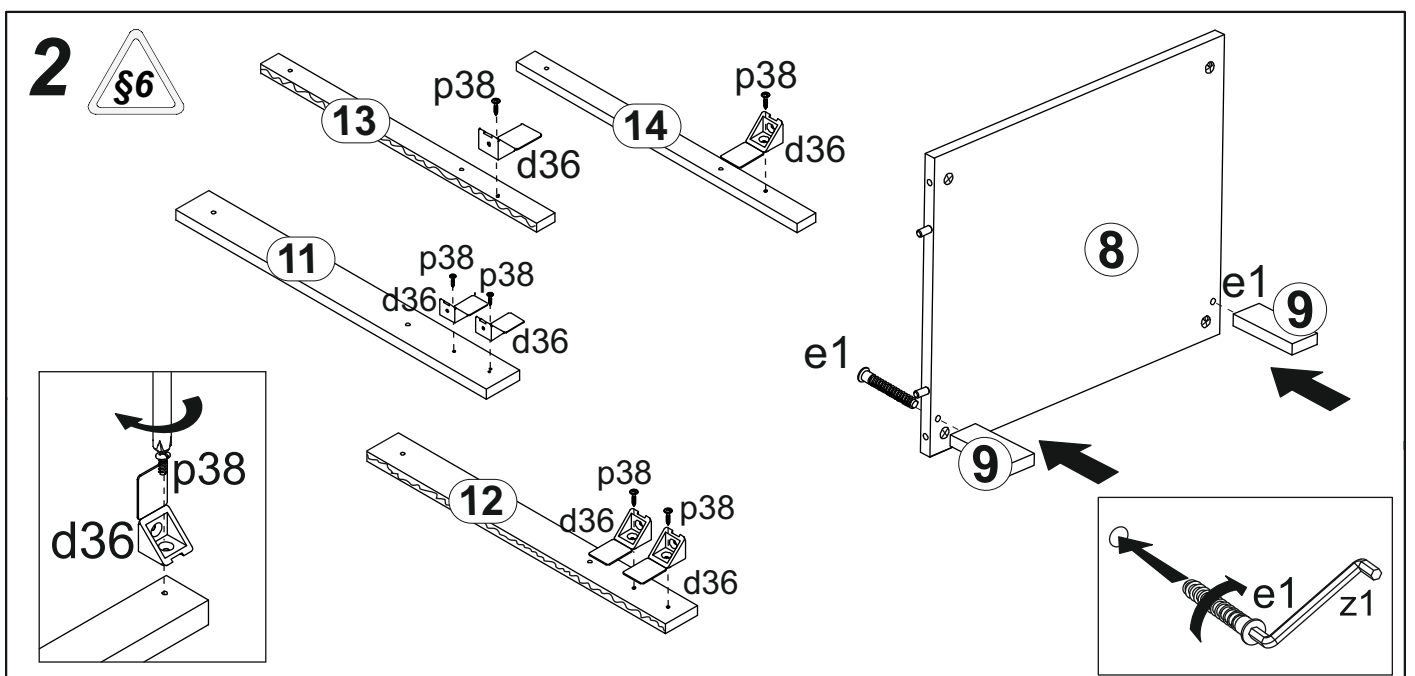
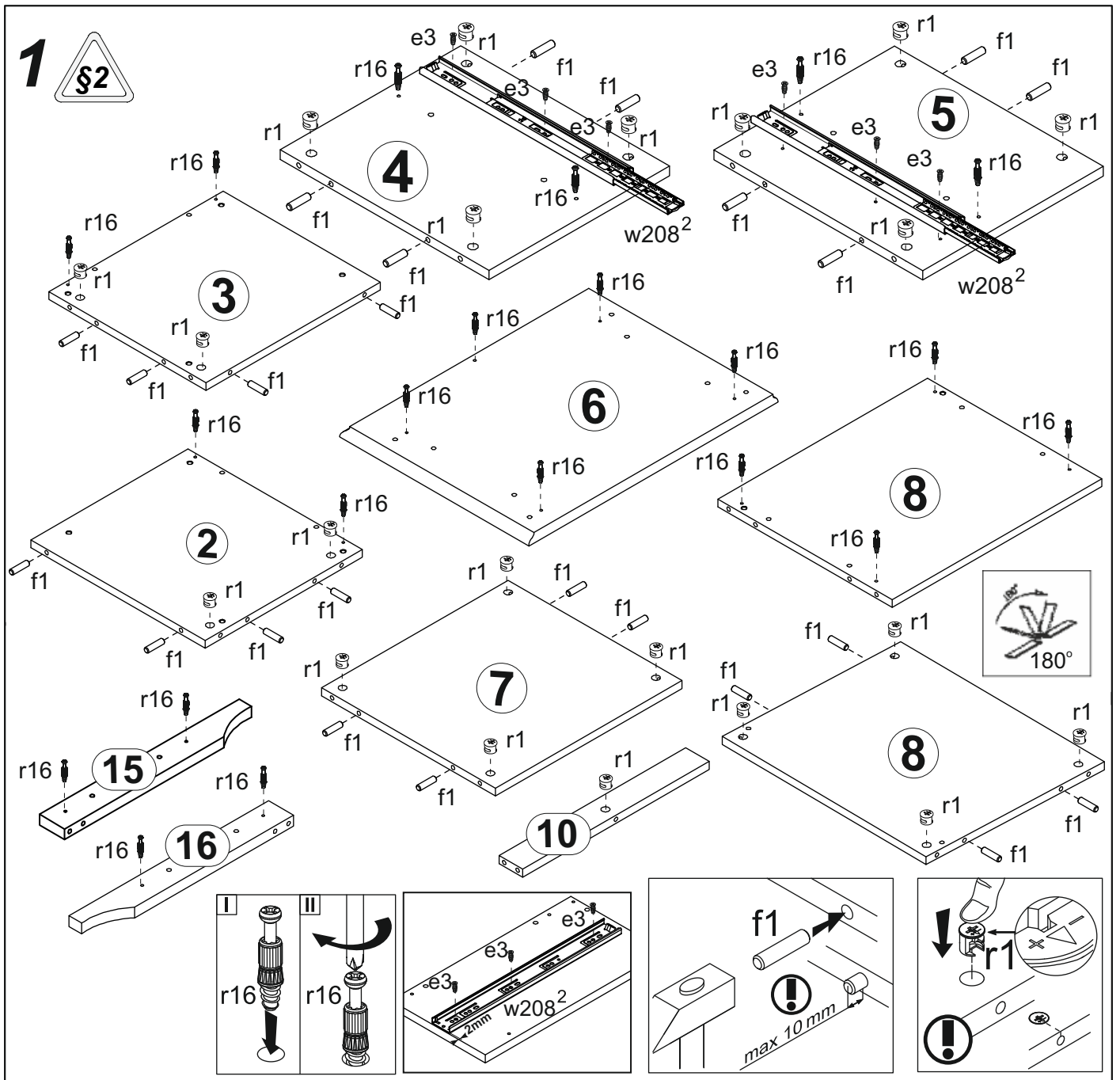

6

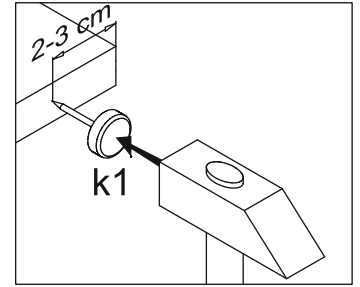
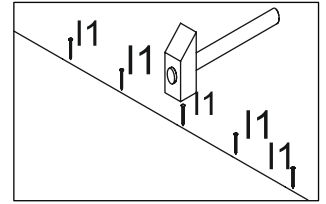
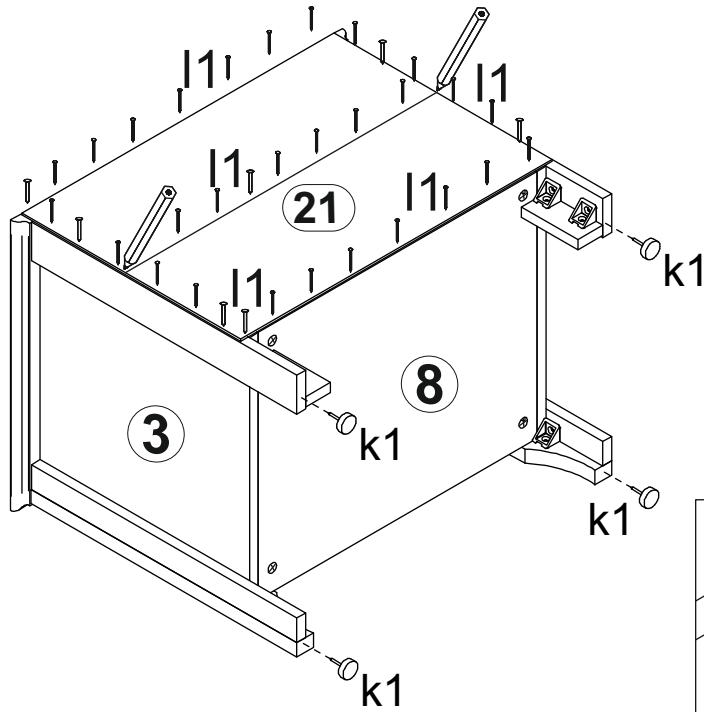
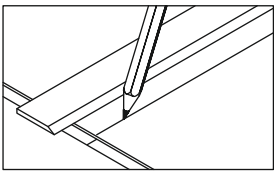
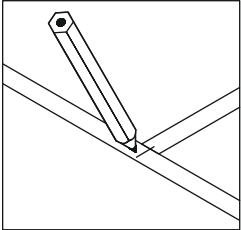
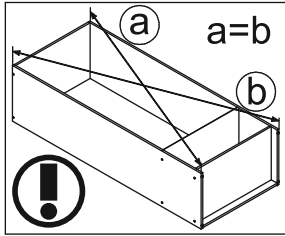

7

